

**Shrub Planting Detail**

No Scale

2  
K2

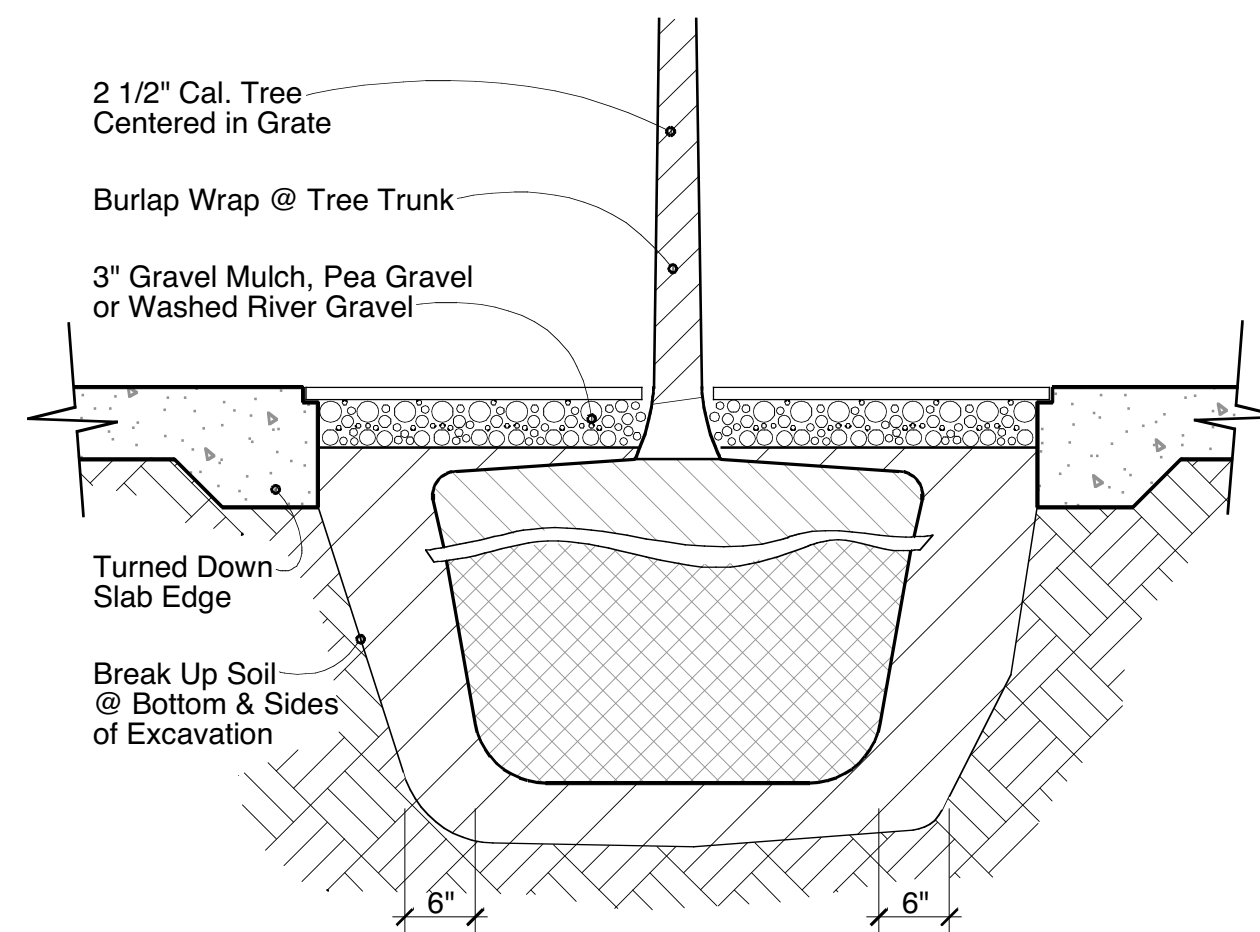

**Tree Pit Detail**

No Scale

4  
K2

**Landscape Notes:**

- Standards for tree sizes shall be at the time of installation.
- Tree installation is planned for May 30, 2013.
- Trees shall have a minimum caliper diameter of 2 1/2" measured 6' above grade.
- Trees shall have a clear trunk, wrapped in burlap w/ no branches less than 6' above grade.
- Tree roots shall be balled and wrapped in burlap.
- Trees shall be 12'-14" in height with a maximum height of 16'.
- Trees shall have a minimum 28" diameter & 18" deep rootball.
- Landscape areas to receive #3 Tree Bark Mulch ground cover.
- Sight triangles are to have no obstructions above 1'-0" in height.

**Planting Legend**

Mark	Common Name	Botanical Name
T1	Autumn Gold	Ginkgo Biloba
S1	Chinese Juniper Shrubs	Juniperis Chinesis
S2	Creeping Juniper	Juniperis Horizontalis

The undersigned Architect, registered in the State of Illinois, acknowledges that the landscape planting plan and construction details shown on the attached landscape drawings for the property at 3905-23 North Western Ave. Chicago, IL 60618 has been designed in accordance with the requirements of Title 10, Chapter 32 of the Chicago Municipal Code, the landscaping standards of the Chicago Zoning Ordinance and the "Guide to the Chicago Landscaping Ordinance".

John Zachar License# 001-016885

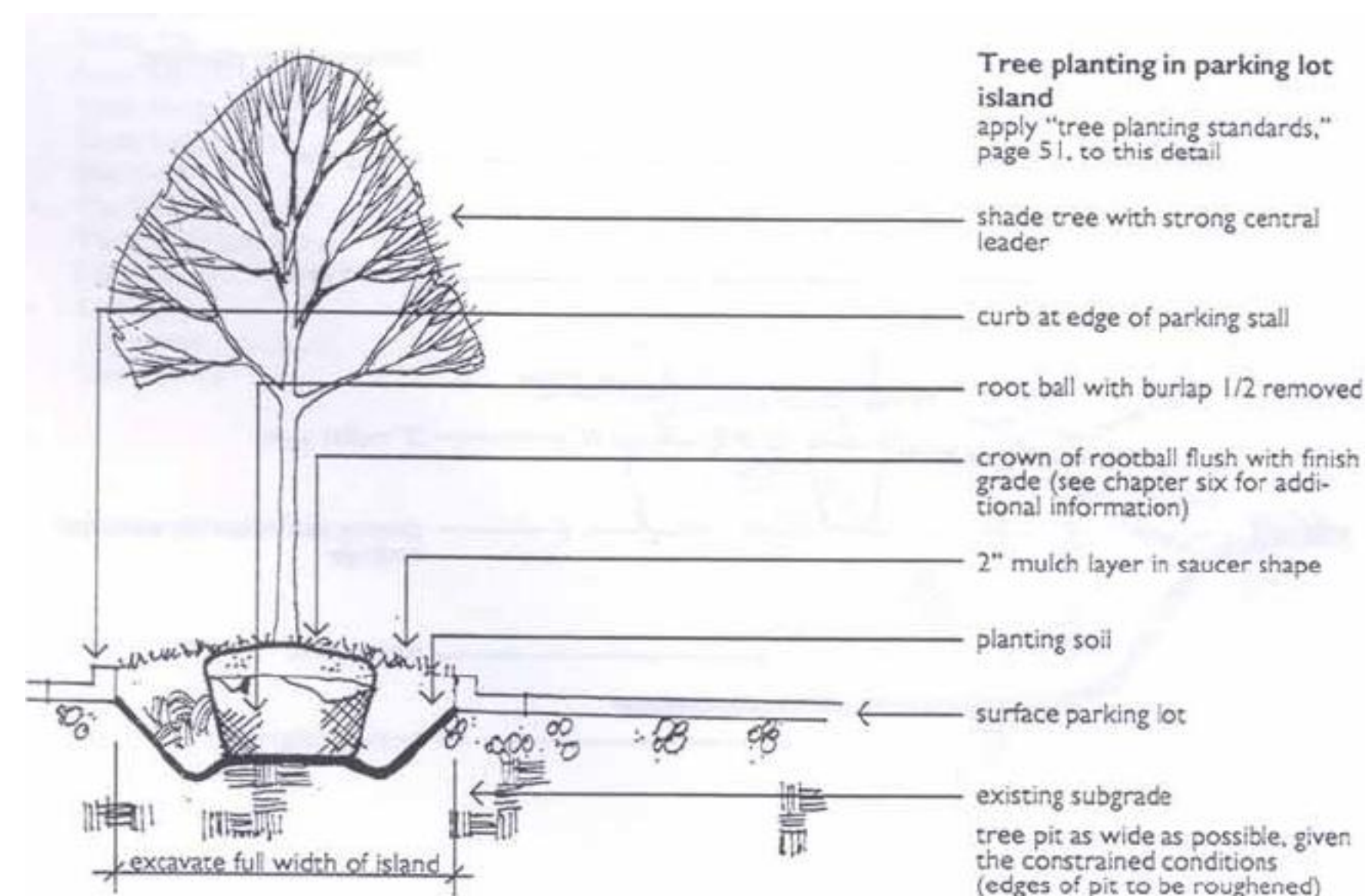
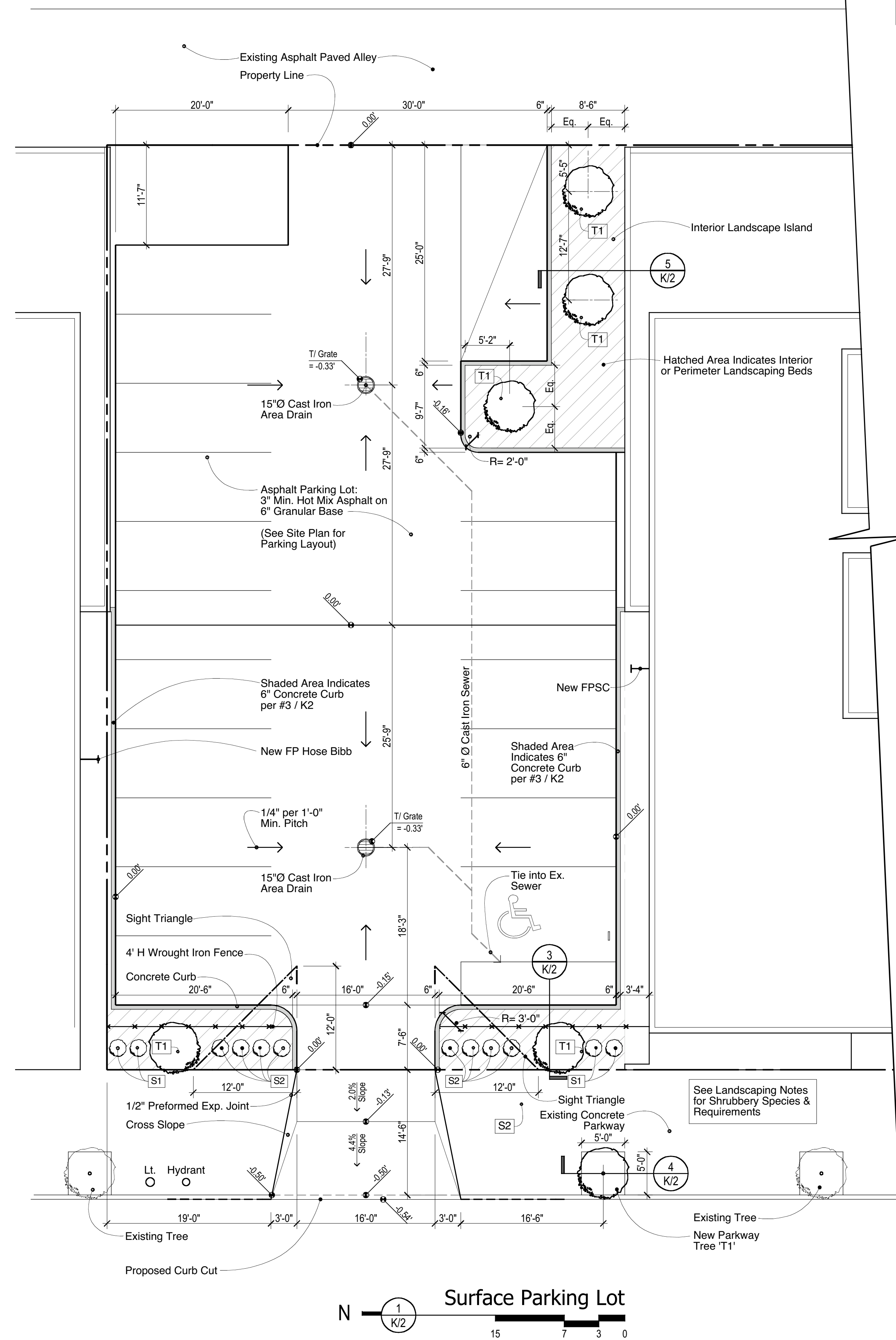
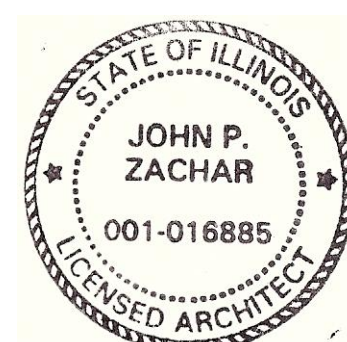

**Tree Planting @ Island**

No Scale

5  
K2

The undersigned acknowledges that the landscape planting plan on the attached landscape drawings for the property at 3905-23 North Western Ave. Chicago, IL 60618 has to the best of the undersigned applicant's knowledge, been designed and will be installed, maintained and replaced as required, by current and subsequent owners in accordance with the requirements of Title 10, Chapter 32 of the Chicago Municipal Code, the landscaping standards of the Chicago Zoning Ordinance and the "Guide to the Chicago Landscaping Ordinance".

Existing parkway and on-site interior trees are to be protected while project is under construction and will be replaced by current and subsequent owner if damaged.

John Russo, Owner, HP-Ventures Group.

for Driveway Permit  
01.05.13  
Landscape Revisions  
03.21.13

773.665.9994  
zacharch.com

Zachar architecture

Za

3905-23 North Western Ave.  
App.# 100454306

Parking Plan & Landscape Details

K/2